

A high-resolution time-of-flight range image sensor with a 3-tap lateral electric field charge modulator

Keita Yasutomi, Yuki Morikawa, Shoma Imanishi,
Taishi Takasawa, Keiichiro Kagawa, Shoji Kawahito

Research Institute of Electronics, Shizuoka University,
3-5-1 Johoku, Hamamatsu, 432-8011, Japan

email: kyasu@idl.rie.shizuoka.ac.jp TEL: +81-53-478-1342 FAX: +81-53-412-5481

1. Introduction

Recently, various time-of-flight (TOF) range imagers [1-4] have been developed, and are becoming popular in 3D acquisition cameras. This is because TOF range imagers have a high-speed capturing capability, and their millimetric range resolutions are sufficient for their applications such as gesture recognition. However, to apply the TOF range imagers to contactless 3D scanners, further higher range resolution is strongly desired. This paper presents a TOF range imager with 140 μm range resolution of a single frame, which corresponds to sub-picosecond time resolution. The developed TOF range imager employs a three-tap lock-in pixel with draining structure, which allows us to enhance a utilization efficiency for a received light. A self-calibration technique [5] for a clock skew of column-parallel gating clocks is introduced to the TOF measurement with the 3-tap lock-in pixel, which shorten calibration time to be several tens of μs .

2. Sensor Architecture

Figure 1 shows a TOF measurement with an impulse photocurrent response [4] by using a 3-tap lock-in pixel. In this paper, the lock-in pixel is implemented by a 3-tap lateral electric field charge modulator (LEFM) with draining structure as shown in

Fig.1. In the LEFM, 4 sets of gates (G1, G2, G3 and GD) formed along a pinned photodiode creates a lateral electric field in the channel region. Since there are no transfer gates in the channel, a high-speed charge modulation with high modulation contrast can be realized. In the previous work [4], a single-tap lock-in pixel is used, and one frame is divided to three sub-frames to capture different signals by different phase time-windows. As a result, only one third of a received light contributes to the TOF calculation, and the rest is discarded. In this 3-tap LEFM, different 3-phase signals by G1, G2, and G3 can be acquired in a single accumulation cycle. All of the received light between 2 time-windows by G1 and G2 contribute to the TOF calculation.

Figure 2 shows a sensor architecture, pixel circuit, and column-parallel skew calibration circuit. The number of 3-tap LEFMs implemented in a single pixel is 60 with 4.2 μm pitch. The pixel size is 22.4 μm (H) \times 67.2 μm (V). The pixel readout circuits for the 3-tap modulated signals is same as that of the 3T-APS. In order to avoid the measurement defects and to reduce the fixed pattern range errors, a clock skew between pixels or columns has to be canceled, because the photocurrent response is several hundreds of ps. For short calibration time, a new self-calibration technique is developed. The two-stage delay

line is controlled by the output of a bang-bang phase detector (BPD). The BPD detects a phase difference between a column and the reference column, which produces the reference clock for all of columns. Because the load capacitance of inverters in "Clock Tree 2" is designed to be very small, the skew can be neglected. To employ the skew calibration technique to the 3-tap lock-in pixels, a falling edge of G1 is chosen for the calibration. The falling edge determines the end of charge modulation. Another important design issue is the non-overlap clock generation at a pattern generator (PG) in each column for solving the problem of charge sharing between two taps when the two adjacent gate clocks are overlapped each other.

3. Measurement results

The TOF line sensor is implemented in 0.11 μ m CIS technology. The pixel array is 257(H) x 8(V) including TEG pixels. In the measurement, a short pulse laser with the wavelength of 473 nm and pulse width of approximately 80 ps is used. The repetition frequency is 16.7MHz and the number of repetitions is 2,000,000, respectively. With this condition, the integration time and the frame rate are 120 ms and 8.2 fps, respectively. Figure 3 shows a measured distance and resolution as a function of the distance to a white target. In the calculation of estimated distance, a third-order approximation is used to correct a non-linearity due to the impulse response of the LEFM. As a result, a non-linearity below

1%FS is achieved at a measurable range of 28mm. The mean range resolution of 140 μ m is obtained in the measureable range. Figure 4 shows a captured 3D image of a ball with diameter of 20 mm. The image is calculated by 100 frame average.

[1]D.Stoppa et al., "A range image sensor based on 0.18- μ m CMOS imaging technology," IEEE JSSC, vol.46, no.1, 2011.

[2]A. Payne, et al. "A 512x424 CMOS 3D Time-of-Flight CMOS Range Image Sensor Multi-Frequency Photo-Demodulation up to 130MHz and 2GS/s ADC", ISSCC, Dig. Tech. Papers, pp. 134-135, Feb. 2014.

[3] S.M. Han et al., "A 413x240-Pixel Sub-Centimeter Resolution Time-of-Flight CMOS Image Sensor with In-Pixel Background Canceling Using Lateral-Electric-Field Charge Modulators, Dig. Tech. Papers, ISSCC, pp. 130-131 (2014).

[4]K. Yasutomi, et al. "A 0.3mm-Resolution Time-of-Flight CMOS Range Imager with Column-Gating Clock-Skew Calibration," ISSCC Dig. Tech. Papers pp.132-133, Feb. 2014.

[5]L. Miao, K. Yasutomi, et al., "A column-parallel clock skew self-calibration circuit for time-resolved CMOS image sensors" IEICE Electronics Express Vol.12, No.24, pp.1-7. 2015.

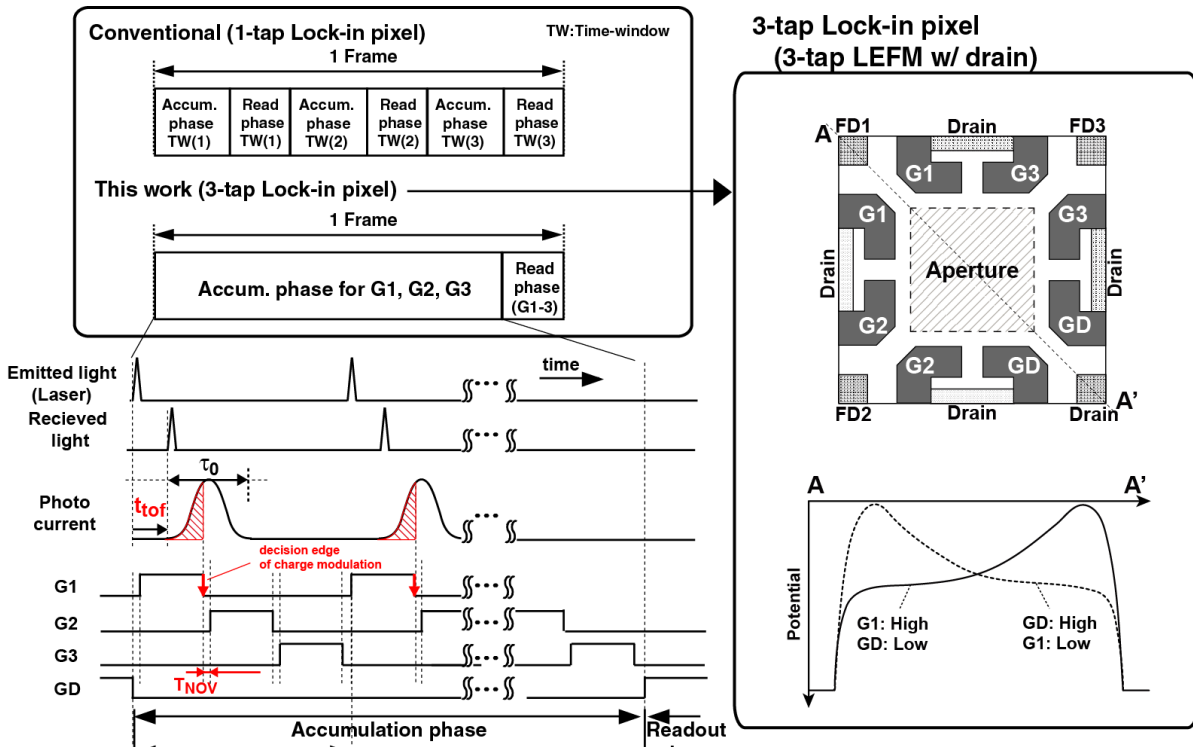

Fig. 1: Time-of-Flight measurement with impulse photocurrent response by using 3-tap LEFM.

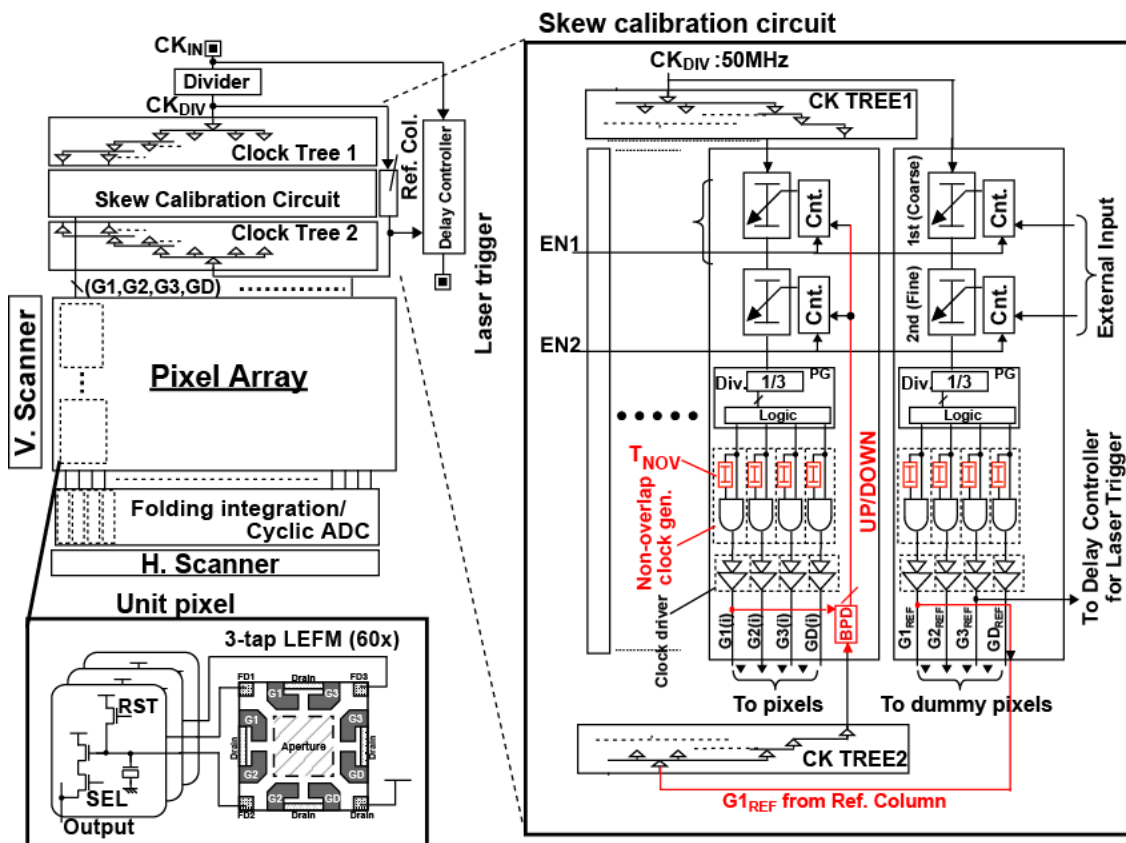

Fig. 2: Sensor Architecture, the pixel circuit, and skew calibration

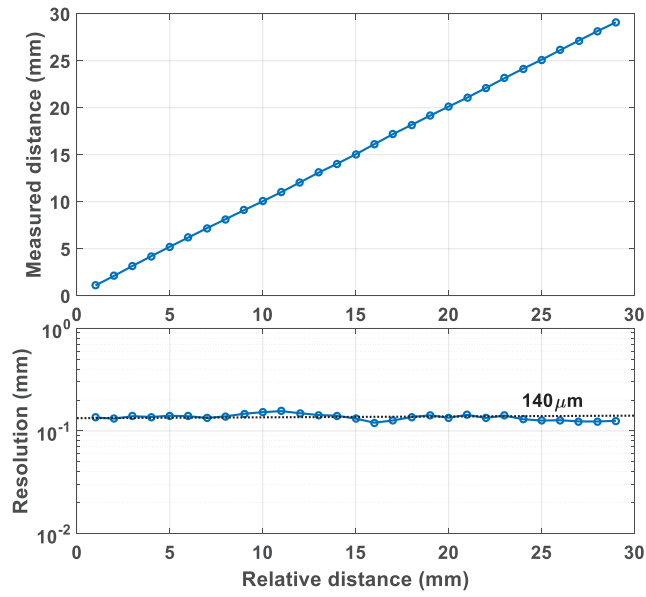

Fig. 3: Measured distance and distance precision as a function of the distance to a white target

Table 1: Performance summary

Technology		0.11- μm CIS
Total pixels		257(H) \times 8 (V)
Effective pixels		192(H) \times 4(V)
Pixel size		22.4(H) \times 67.2(V) μm^2
Frame rate (Integration time 120 ms)		8.2 fps
Repetition frequency (for G1, G2, G3)		16.7 MHz
Skew between pixels		23 ps_{rms}
Emitter	Wavelength	473 nm
	Pulse width	80 ps
	Emitted power	243 μW
Measurable Range		28 mm (Error <1%FS)
Range Resolution (Median)		140 μm (single frame) 55 μm (100 average)

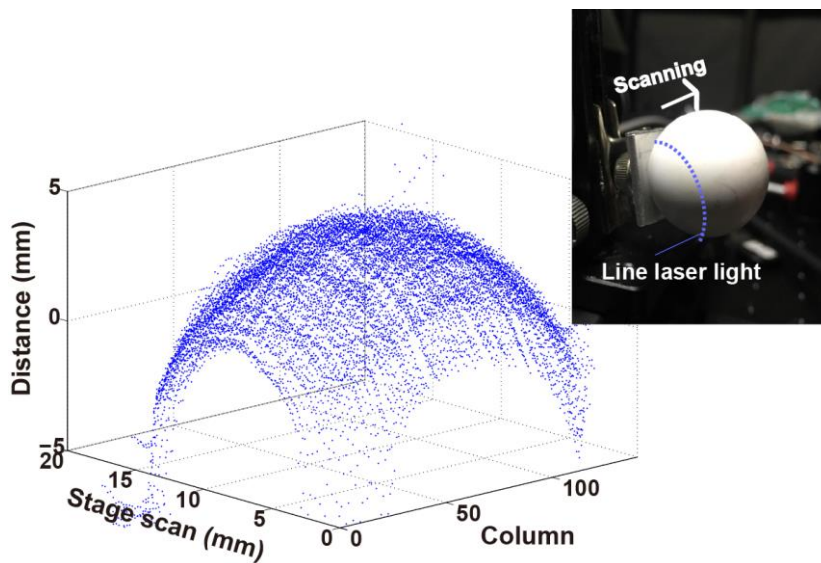

Fig. 4: Captured 3D image of a ball with diameter of 20mm. The image is calculated by 100 frame average.